

PATENT ABSTRACTS OF JAPAN

(11)Publication number : 07-198780
 (43)Date of publication of application : 01.08.1995

(51)Int.Cl. G01R 31/26
 H01L 21/66

(21)Application number : 05-349446 (71)Applicant : Y A SHII KK
 (22)Date of filing : 28.12.1993 (72)Inventor : KASAI NORIAKI
 OTSUBO YUTAKA

(54) TEST HANDLER

(57)Abstract:

PURPOSE: To provide a test handler which can reduce the cost of tests and is free from time loss.

CONSTITUTION: A test handler which evaluates and discriminates the electric characteristics of a semiconductor device 20 mounted on a socket board 3 through a scramble board 4 in which wiring routes are made to cross each other in a printed board so as to change the signal receiving/delivering IO pin used for delivering and receiving signals to and from a test head section 52 in corresponding to the kind of circuit used in the device 20 at the test head section 52 is constituted so that the scramble board 4 can be automatically attached to or detached from the contact board 10 of the test head section 52 through the carrying route for carrying the socket board 3 before starting the supply of the board 3.

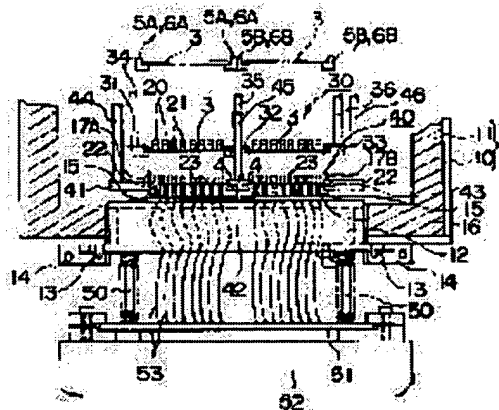

LEGAL STATUS

[Date of request for examination]

[Date of sending the examiner's decision of rejection]

[Kind of final disposal of application other than
the examiner's decision of rejection or
application converted registration]

[Date of final disposal for application]

[Patent number]

[Date of registration]

[Number of appeal against examiner's
decision of rejection]

[Date of requesting appeal against examiner's
decision of rejection]

[Date of extinction of right]

Copyright (C); 1998,2003 Japan Patent Office

* NOTICES *

Japan Patent Office is not responsible for any damages caused by the use of this translation.

1. This document has been translated by computer. So the translation may not reflect the original precisely.
2. **** shows the word which can not be translated.
3. In the drawings, any words are not translated.

CLAIMS

[Claim(s)]

[Claim 1] The scramble board which made the wiring path beforehand interwoven with each other within a printed circuit board in order to make IO pin of signal delivery in the test section change corresponding to the circuit form of a semiconductor device is minded. It is the test handler which carries out evaluation distinction of the electrical characteristics for the semiconductor device carried in the socket board in the test section. The test handler characterized by coming to constitute said scramble board in the predetermined location of said test section removable automatically through the conveyance path which conveys this socket board before said socket board supply initiation.

[Translation done.]

* NOTICES *

Japan Patent Office is not responsible for any damages caused by the use of this translation.

1. This document has been translated by computer. So the translation may not reflect the original precisely.
2. **** shows the word which can not be translated.
3. In the drawings, any words are not translated.

DETAILED DESCRIPTION

[Detailed Description of the Invention]

[0001]

[Industrial Application] This invention relates to the test handler for carrying out the coincidence test of the electrical characteristics of two or more semiconductor devices.

[0002]

[Description of the Prior Art] When carrying out the coincidence test of two or more semiconductor devices by the test handler, the socket board furnished with two or more IC sockets carrying a semiconductor device is used. In this case, in order to make IO (Inn out) pin of signal delivery in the test section change corresponding to the circuit form of a semiconductor device, the scramble circuit which made the wiring path beforehand interwoven with each other within a printed circuit board is needed.

[0003] Conventionally, in this test handler, the scramble circuit is beforehand included in the spacing frame of the test section the approach of testing by conveying the unification board which included the scramble circuit in the socket board at one the 1st in the test section, and the 2nd, and the approach of testing by conveying only a socket board in the test section is learned.

[0004]

[Problem(s) to be Solved by the Invention] Since the 1st approach of the above includes the scramble circuit in the socket board beforehand, it needs very many unified socket boards. By the way, the socket board incorporating a scramble circuit was very expensive (about about 40 times) compared with the socket board of a simple substance, and since it needed many such unified expensive socket boards, it had the problem that test cost started.

[0005] The 2nd approach of the above needs the activity which exchanges the spacing frame attached in the test section at the time of form modification of the semiconductor device to test. Since the test section is generally prepared in the thermostat, exchange of a spacing frame takes skill and great time amount to it. Moreover, by the time a thermostat rises to predetermined temperature, a time loss will occur.

[0006] The purpose of this invention cancels the trouble of the above-mentioned conventional technique, and is to offer a test handler without reduction and the time loss of test cost.

[0007]

[Means for Solving the Problem] The configuration of this invention for attaining the above-mentioned purpose minds the scramble board which made the wiring path beforehand interwoven with each other within a printed circuit board in order to make IO pin of signal delivery in the test section change corresponding to the circuit form of a semiconductor device. It is the test handler which carries out evaluation distinction of the electrical characteristics for the semiconductor device carried in the socket board in the test section. It is characterized by coming to constitute said scramble board in the predetermined location of said test section removable automatically through the conveyance path which conveys this socket board before said socket board supply initiation.

[0008]

[Function] A scramble board is automatically set to the test section through the conveyance path of a

BEST AVAILABLE COPY

socket board before socket board supply initiation. After that, the socket board carrying the semiconductor device to test is electrically connected to the scramble board set to the test section through the conveyance path, and a test is performed. At the time of a form switch, said scramble board is discharged through the conveyance path of a socket board, and it is set to the test section by the actuation which a new scramble board described above. Thus, only by the number set to the test section, since a scramble board is good, it can aim at reduction of test cost sharply. Moreover, since a scramble board passes along the conveyance path of a socket board automatically and is attached and removed by the test section, even if the test section is prepared in the thermostat, while not needing skill, there is no time loss.

[0009]

[Example] Hereafter, drawing 1 and drawing 2 explain one example of this invention. As shown in drawing 1, in the internal lower part of the thermostat 1 which consists of a core box, it has the test section 2, and 2 sets of supply guide rails 5A and 5B which guide at a time two the socket boards 3 and the scramble boards 4 which carry out a postscript above the test section 2, respectively, and 2 sets of discharge guide rails 6A and 6B which guide the socket board 3 and the scramble board 4 which are discharged from the test section 2 are formed in the upper both sides of the test section 2 at it. The supply conveyor 7 which conveys the socket board 3 and the scramble board 4 in a thermostat 1 from the exterior is arranged in the edge side of said supply guide rails 5A and 5B by the supply guide rails 5A and 5B and the right angle. The discharge conveyor 8 which conveys the socket board 3 and the scramble board 4 outside from the inside of a thermostat 1 is arranged by the discharge guide rails 6A and 6B and the right angle also like the edge side of said discharge guide rails 6A and 6B. In the edge of the supply conveyor 7 and the discharge conveyor 8, the magazines 9A and 9B for containing the socket board 3 in the form which carries out a laminating are arranged.

[0010] As shown in drawing 2, said thermostat 1 consists of structure which formed the heat insulator 11 in the interior of the frame 10 of a core box, and the spacing frame 12 is arranged in the test section 2 of a thermostat 1. The spacing frame 12 is positioned with the gage pin 13 fixed to the inferior surface of tongue of a thermostat 1, and is clamped by the clumper 14. Two contact boards 15 which consist of the completely same structures are being fixed to the top face of the spacing frame 12. A contact board 15 has a male connector 16 on the top face. In the left-hand side section of the left-hand side contact board 15 Positioning guide-pins 17A which is inserted in the locating hole (not shown) of the socket board 3 and the scramble board 4, and positions this socket board 3 and the scramble board 4 is fixed. Positioning guide-pins 17B which is inserted in the locating hole (not shown) of the socket board 3 and the scramble board 4, and positions this socket board 3 and the scramble board 4 also like the right-hand side section of the right-hand side contact board 15 is being fixed.

[0011] Said socket board 3 has IC socket 21 carrying a semiconductor device 20. In order that said scramble board 4 may make IO (Inn out) of signal delivery on a circuit tester change corresponding to the circuit form of a semiconductor device 20, it has the female connector 22 which a wiring circuit is made to come to be each other interwoven with within a printed circuit board beforehand, and becomes said male connector 16 and pair on the inferior surface of tongue, and has contact 23 of the spring nature which contacts the terminal area of the socket board 3 on the top face.

[0012] A socket board maintenance means 30 to hold two socket boards 3, and a scramble board maintenance means 40 to hold two scramble boards 4 are established above said spacing frame 12. It is fixed to the vertical driving shafts 34, 35, and 36 with which the vertical drive of said socket board maintenance means 30 is carried out by the driving means to which it has three holders 31, 32, and 33 with which the both-sides edge of the two socket board 3 is inserted, and holders 31, 32, and 33 do not illustrate them. It has similarly three holders 41, 42, and 43 with which the both-sides edge of two scramble boards 4 is inserted for said scramble board maintenance means 40, and holders 41, 42, and 43 are being fixed to the vertical driving shafts 44, 45, and 46 by which a vertical drive is carried out by the driving means which is not illustrated. Here, holders 31, 32, and 33 are always located more nearly up than holders 41, 42, and 43.

[0013] A mother board 51 is fixed to the inferior surface of tongue of said spacing frame 12 through a

bearing bar 50, and the mother board 51 is being fixed to the test head 52. And the wire 53 is connected to the contact board 15 and the mother board 51 so that the terminal of said contact board 15 may flow electrically for the terminal of a test head 52.

[0014] Next, an operation is explained. First, the scramble board 4 which suits the socket board 3 carrying the semiconductor device 20 to test is supplied in the two-piece thermostat 1. In this case, the vertical drive of the vertical driving shafts 44, 45, and 46 is carried out, and it is standing by so that the slot of the holders 41, 42, and 43 of the scramble board maintenance means 40 may correspond to the conveyance path of the supply guide rails 5A and 5B, and the holders 31, 32, and 33 of the socket board maintenance means 30 are located more nearly up than the conveyance path of the supply guide rails 5A and 5B. When two scramble boards 4 are conveyed by supply conveyor 7 in a thermostat 1 from the exterior, the scramble board 4 of these two individuals is made to carry out a positioning halt in the side of the supply guide rails 5A and 5B, respectively.

[0015] Next, with the pusher which is not illustrated, the scramble board 4 is extruded by the supply guide rails 5A and 5B from the supply conveyor 7. The scramble board 4 transferred to the supply guide rails 5A and 5B is sent by the feed blade which is not illustrated, and is inserted in the orientation of the slot of holders 41, 42, and 43. Next, the vertical driving shafts 44, 45, and 46 descend, and after the locating hole of the scramble board 4 is inserted in the positioning guide pins 17A and 17B and the scramble board 4 is positioned, the female connector 22 of the scramble board 4 is combined with the male connector 16 of a contact board 15. Henceforth, as long as there is no form modification (i.e., unless a semiconductor device 20 and the socket board 3 corresponding to it are changed), holders 41, 42, and 43 hold the condition of having described above.

[0016] It moves to test actuation of a semiconductor device 20 in the condition of having described above. Magazine 9A which contained the socket board 3 on which the semiconductor device 20 was carried in IC socket 21 is set. moreover, magazine 9B -- an empty thing set -- it carries out. The vertical driving shafts 34, 35, and 36 of the socket board maintenance means 30 drive first, it descends, and the slot of holders 31, 32, and 33 stands by corresponding to the conveyance path of the supply guide rails 5A and 5B. The socket board 3 is supplied to the two-piece supply conveyor 7 from magazine 9A. And by supply conveyor 7, from the exterior, it is conveyed in a thermostat 1 and a positioning halt is carried out in the side of the supply guide rails 5A and 5B, respectively. Next, with the pusher which is not illustrated, the socket board 3 is extruded by the supply guide rails 5A and 5B from the supply conveyor 7. The scramble board 4 transferred to the supply guide rails 5A and 5B is sent by the feed blade which is not illustrated, and is inserted in the orientation in the slot of holders 31, 32, and 33.

[0017] Next, the vertical driving shafts 34, 35, and 36 descend, and after the locating hole of the socket board 3 is inserted in positioning guide-pins 17A and positioning guide-pins 17B and is positioned, the terminal area of the socket board 3 contacts contact 23 of the scramble board 4. Evaluation distinction of the electrical characteristics of a semiconductor device 20 is carried out with the circuit tester connected to the test head 52 in this condition. The result of this evaluation distinction is memorized by the host computer which is not illustrated. Moreover, if the socket board 3 is inserted into holders 31 and 32 and 33 as described above Next, the socket board 3 carrying the semiconductor device 20 tested is supplied to the two-piece supply conveyor 7 from magazine 9A. By supply conveyor 7, it is conveyed to the side of the supply guide rails 5A and 5B, is further transferred to the supply guide rails 5A and 5B from the supply conveyor 7, and stands by on supply guide-rail 5A and 5B.

[0018] Termination of the test of a semiconductor device 20 raises the vertical driving shafts 34, 35, and 36 so that the slot of holders 31, 32, and 33 may correspond to the conveyance path of the supply guide rails 5A and 5B and the discharge guide rails 6A and 6B. And the socket board 3 held at holders 31, 32, and 33 is extruded by the discharge guide rails 6A and 6B, and is further conveyed on the discharge conveyor 8 from the discharge guide rails 6A and 6B by the feed blade which is not illustrated. Then, by discharge conveyor 8, it is discharged by the exterior of a thermostat 1 and is contained by magazine 9B. Moreover, if the socket board 3 is extruded by the discharge guide rails 6A and 6B from holders 31, 32, and 33, the socket board 3 tested by the degree which is standing by to the supply guide rails 5A and 5B will be sent into holders 31, 32, and 33. Henceforth, the above mentioned actuation is repeated, one by

one, supply conveyance of even two socket boards 3 is carried out, and the semiconductor device 20 carried in this socket board 3 is tested.

[0019] When the form of the semiconductor device 20 to test is changed, the vertical driving shafts 44, 45, and 46 of the scramble board maintenance means 40 go up, and it is made to correspond to the slot of holders 41, 42, and 43 by the conveyance path of the supply guide rails 5A and 5B and the discharge guide rails 6A and 6B. And the scramble board 4 held at holders 41, 42, and 43 is extruded by the discharge guide rails 6A and 6B, and is further conveyed on the discharge conveyor 8 from the discharge guide rails 6A and 6B by the feed blade which is not illustrated. Then, it is discharged by the exterior of a thermostat 1 by discharge conveyor 8. Next, the scramble board 4 which suits the socket board 3 carrying the semiconductor device 20 to test is supplied to the two-piece supply conveyor 7. Henceforth, the scramble board 4 is held by the above mentioned actuation at the holders 41, 42, and 43 of the scramble board maintenance means 40, and it is combined with a contact board 15. Then, if the socket board 3 is supplied to the supply conveyor 7, a semiconductor device 20 will be tested one by one by the above mentioned actuation.

[0020] Thus, since the scramble board 4 is good only at two pieces set to the test section 2 according to this example, reduction of test cost can be aimed at sharply. Moreover, since the scramble board 4 passes along the conveyance path (the supply guide rails 5A and 5B and discharge guide rails 6A and 6B) of the socket board 3 automatically and is attached and removed by the test section 2, even if the test section 2 is formed in the thermostat 1, while not needing skill, there is no time loss.

[0021] In addition, in the above-mentioned example, since the case where the semiconductor device 20 which supplies the two socket board 3 to coincidence, and is carried in the two socket board 3 was tested was explained, two scramble boards 4 were needed. However, when testing the semiconductor device 20 carried in the one socket board 3, it cannot be overemphasized that the scramble board 4 is good at one piece.

[0022]

[Effect of the Invention] According to this invention, the scramble board which made the wiring path beforehand interwoven with each other within a printed circuit board in order to make IO pin of signal delivery in the test section change corresponding to the circuit form of a semiconductor device is minded. It is the test handler which carries out evaluation distinction of the electrical characteristics for the semiconductor device carried in the socket board in the test section. Since it comes to constitute said scramble board in the predetermined location of said test section removable automatically through the conveyance path which conveys this socket board before said socket board supply initiation, reduction and the time loss of test cost are lost.

[Translation done.]

* NOTICES *

Japan Patent Office is not responsible for any damages caused by the use of this translation.

1. This document has been translated by computer. So the translation may not reflect the original precisely.
2. **** shows the word which can not be translated.
3. In the drawings, any words are not translated.

DESCRIPTION OF DRAWINGS

[Brief Description of the Drawings]

[Drawing 1] It is the important section sectional view showing one example of the test handler which becomes this invention.

[Drawing 2] It is the top view showing the whole outline configuration.

[Description of Notations]

- 1 Thermostat
- 2 Test Section
- 3 Socket Board
- 4 Scramble Board
- 5A, 5B Supply guide rail
- 6A, 6B Discharge guide rail
- 7 Supply Conveyor
- 8 Discharge Conveyor
- 12 Spacing Frame
- 15 Contact Board
- 20 Semiconductor Device
- 21 IC Socket
- 30 Socket Board Maintenance Means
- 40 Scramble Board Maintenance Means
- 52 Test Head

[Translation done.]

* NOTICES *

Japan Patent Office is not responsible for any damages caused by the use of this translation.

1. This document has been translated by computer. So the translation may not reflect the original precisely.
2. **** shows the word which can not be translated.
3. In the drawings, any words are not translated.

DRAWINGS

[Drawing 1]

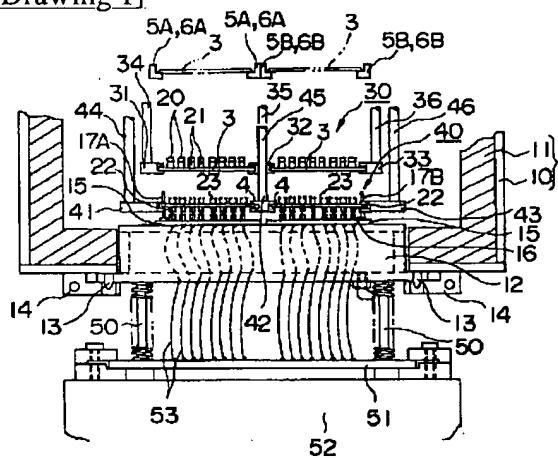

- 1 : 恒温槽
- 2 : テスト部
- 3 : ソケットボード
- 4 : スクランプルボード
- 5A, 5B : 供給ガイドレール
- 6A, 6B : 排出口ガイドレール
- 12 : スペースングフレーム
- 15 : コンタクトボード
- 20 : 半導体デバイス
- 21 : ICソケット
- 30 : ソケットボード保持手段
- 40 : スクランプルボード保持手段
- 52 : テストヘッド

[Drawing 2]

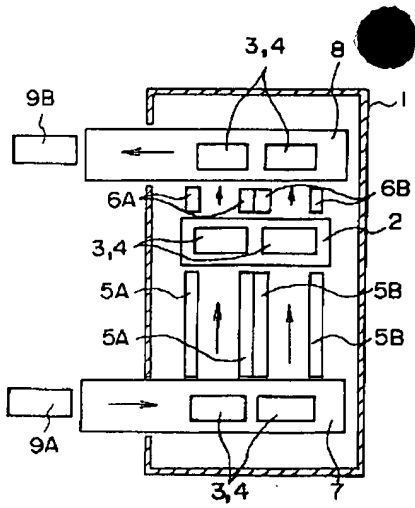

- 1: 保護箱
- 2: テスト部
- 3: ソケットボード
- 4: スクランブルボード
- 5A, 5B: 供給ガイドレール
- 6A, 6B: 排出ガイドレール
- 7: 供給コンベア
- 8: 排出コンベア

[Translation done.]